

Modelling Luyben's Chemical Processes with

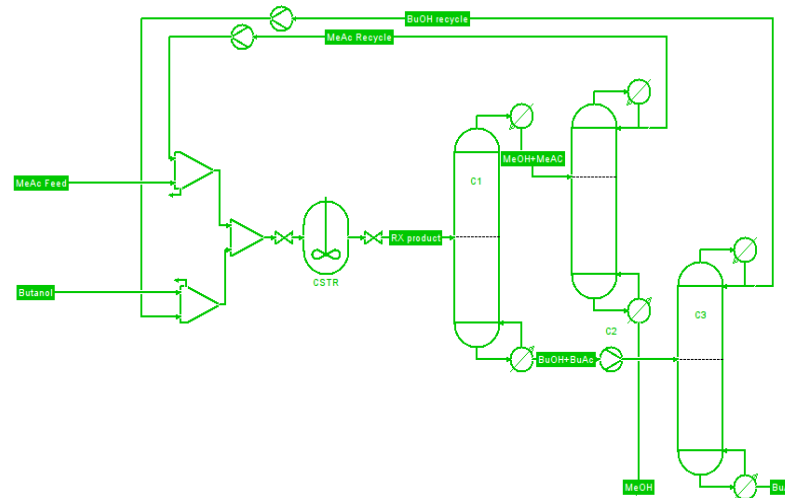

COCO + ChemSep

Ross Taylor, Harry Kooijman and Brett Walker

Clarkson University, Potsdam, New York

Jasper van Baten

AmsterCHEM, Las Rozas, Spain

Outline

- **Luyben's Flowsheets**
- **Introduction to COCO**
- **What is CAPE-OPEN?**
- **Example flowsheets**
- **Lessons learned**

Luyben's Flowsheets

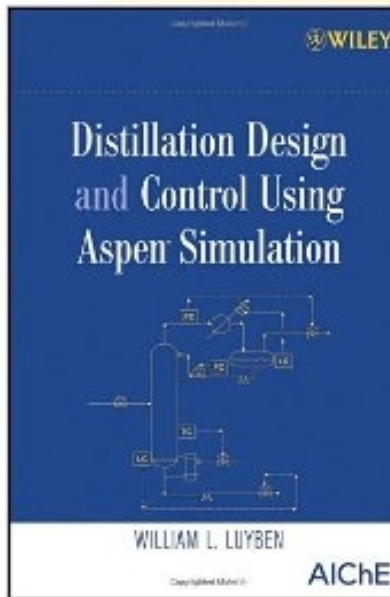

2006

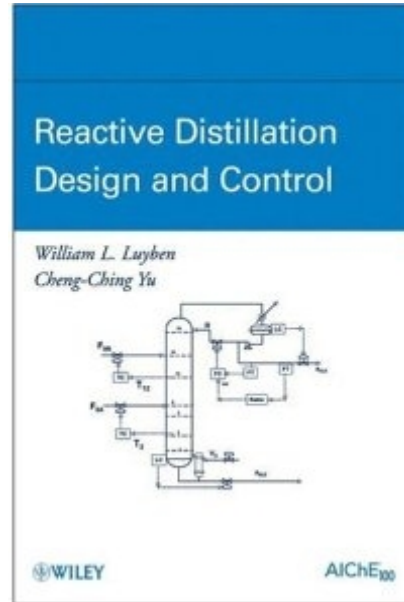

2008

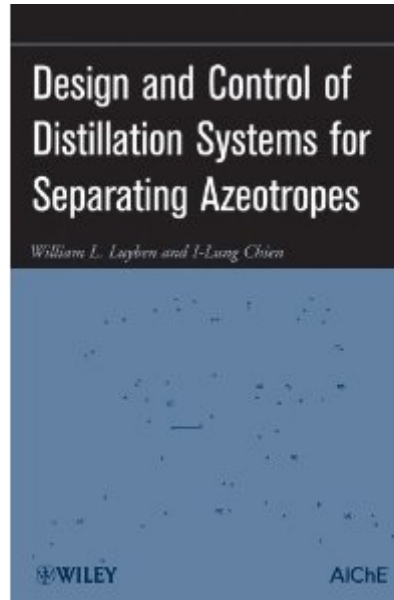

2010

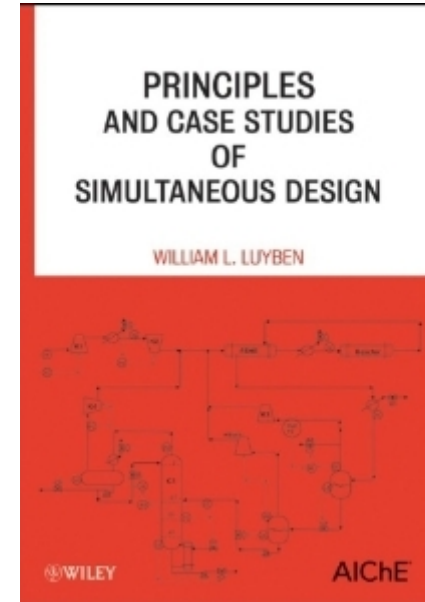

2011

Luyben's Flowsheets

- **Class D: Distillation Only**
 - Columns, heat exchangers, recycle
 - ***NO (separate) reactors***

- **Class C: Complicated Flowsheets**
 - Columns, heat exchangers, recycle
 - ***Chemical reactors***
 - ***Other unit operations***

Luyben's Flowsheets

➤ **Class D: Distillation Only**

- Pressure Swing Azeotropic Distillation
- Extractive Distillation
- Heterogeneous Binary/Ternary Azeotropes
- Reactive Distillation

➤ **Class C: Complicated Flowsheets**

- Cumene Process
- Butyl Acetate Process
- Ethanol – Water with membrane unit

Luyben's Flowsheets (with Aspen Simulation)

- **Analysis**
- **Steady State Design**
- **Optimization**
- **Process Dynamics**
- **Control**

Luyben's Flowsheets with COCO

- ~~Analysis~~
- **Steady State Design**
- **Optimization**
- ~~Process Dynamics~~
- ~~Control~~



COFE: CAPE-OPEN Flowsheeting Environment

Graphical flowsheeting

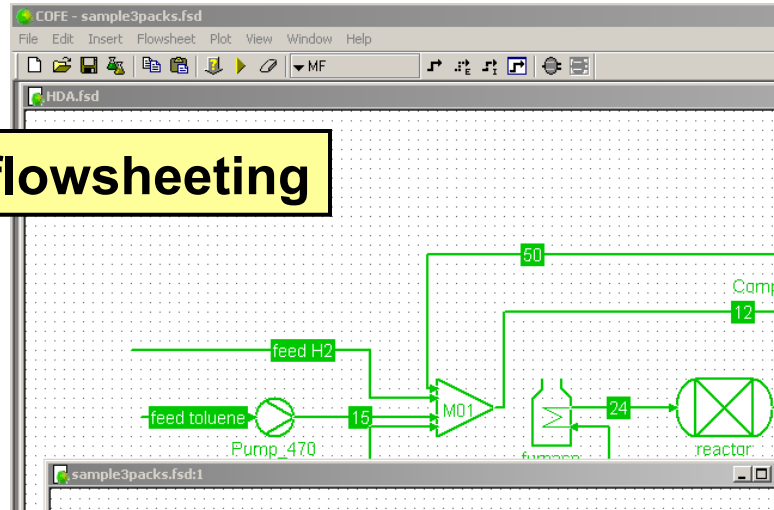

Multiple models

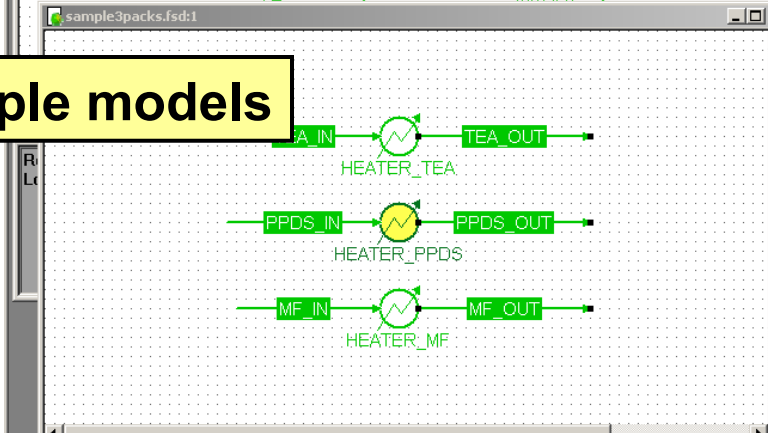

Logging

warning: Material object error in SetProp: invalid phase for temperature in SetProp
warning: Material object error in SetProp: invalid phase for pressure in SetProp
(last 2 messages repeated 1 time)
solving HEATER_MF
Solve finished in 109ms

Graphing

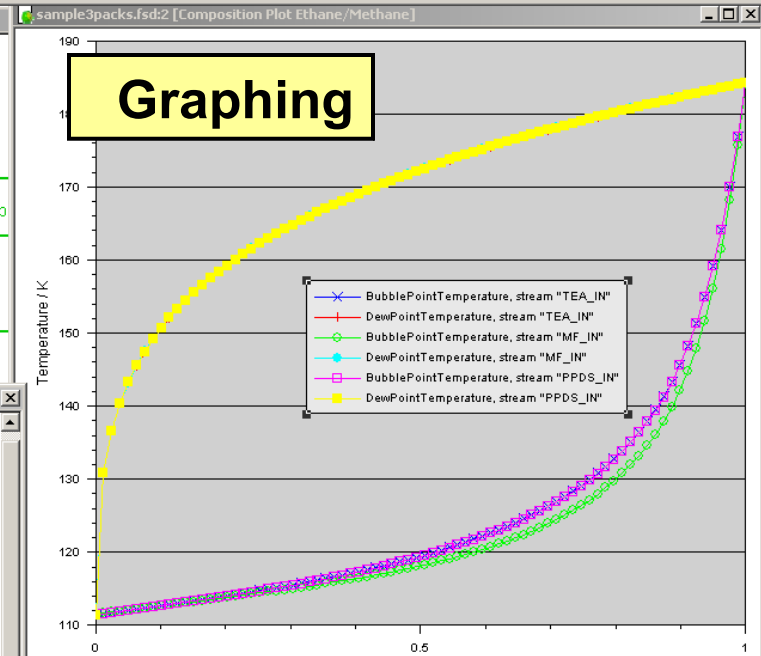

Streams:

name	TEA_OUT	PPDS_OUT	MF_OUT	unit
Stream				
Connections				
Overall				
pressure	1	1	1	bar
temperature	175.16176	175.17004	175.19911	K
mole fraction [Methane]	0.4	0.4	0.4	
mole fraction [Ethane]	0.6	0.6	0.6	
flow	1	1	1	mol / s
MW	24.4592	24.4592	24.4592	g / mol
Phase Fractions				
molar phaseFraction [Vapor]	0.99405972	0.99343065	0.99370008	
molar phaseFraction [Liquid]	0.0059402761	0.0065693453	0.0062999214	
Vapor composition				
Liquid composition				
Overall properties				
Vapor properties				
Liquid properties				

Streams view

Introduction to COCO:



Simulation environment (COFE)



Thermodynamic property package (TEA)



Collection of unit operations (COUSCOUS)



Reaction package (CORN)

Download COCO: <http://www.cocosimulator.org/>

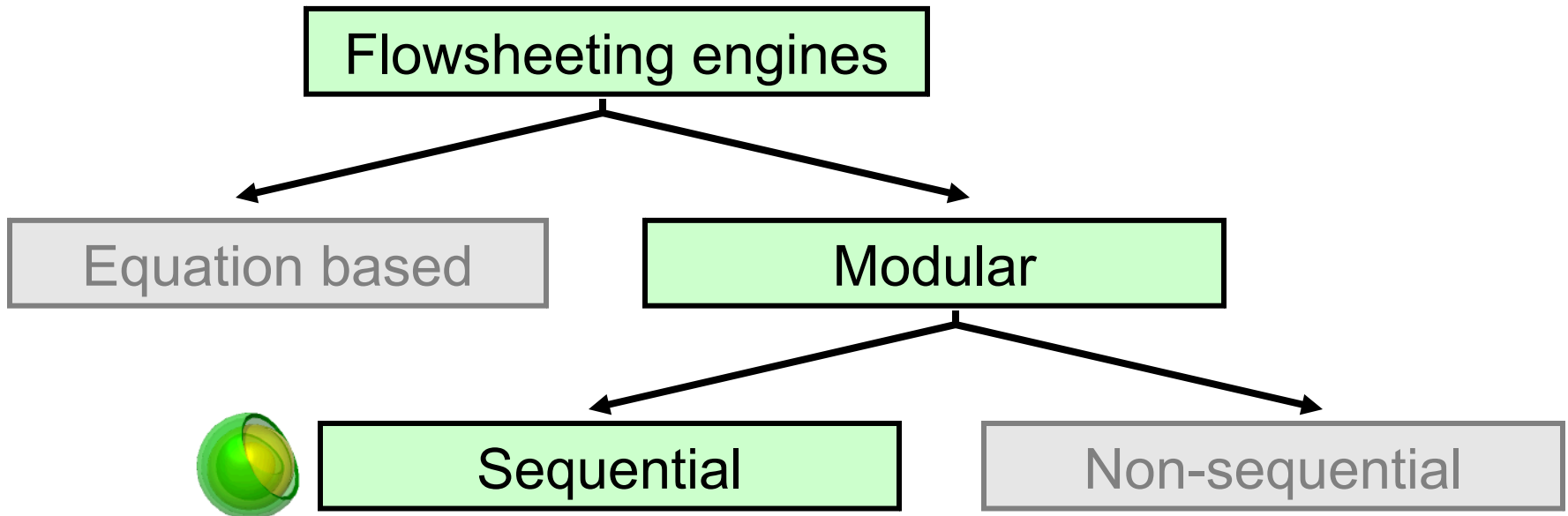
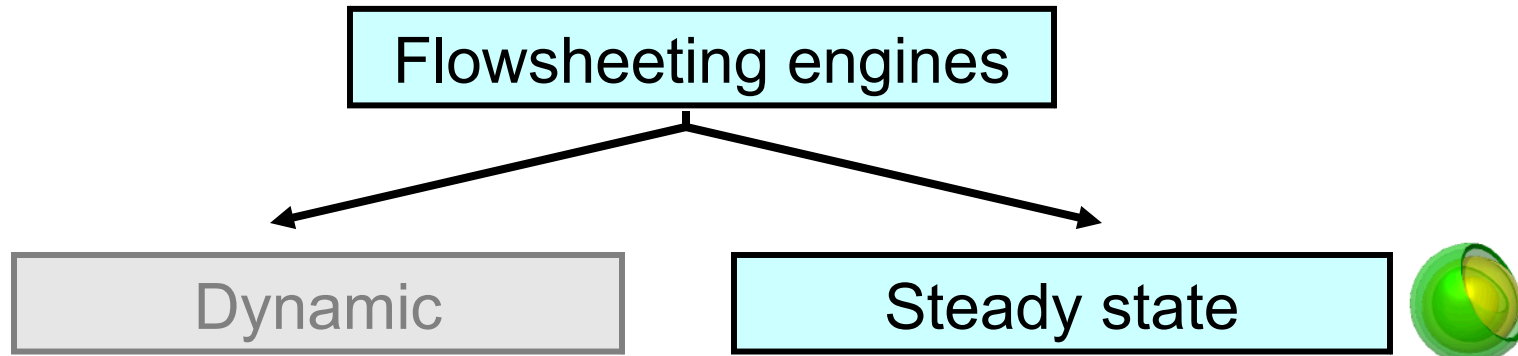



COFE: CAPE-OPEN Flowsheeting Environment

- Breaking recycles by automatic tearing
- Solving recycles by hybrid Newton / Wegstein approach, using reparameterization
- Support for multiple material types, with selection for thermo and sub-set of compounds
- Material, energy and information streams

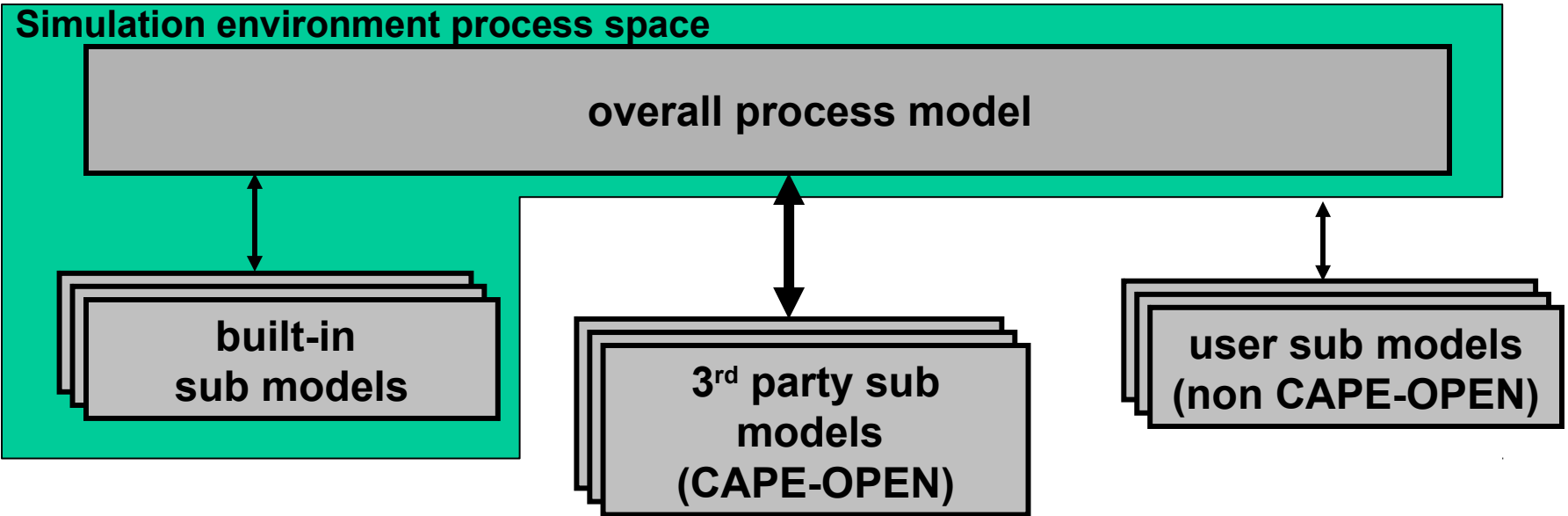

Simulation environment process space

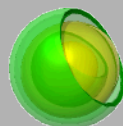

overall process model (COFE)

Thermo models

Unit operation models

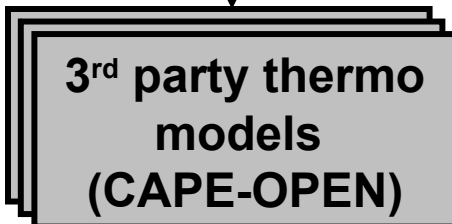

Reaction models

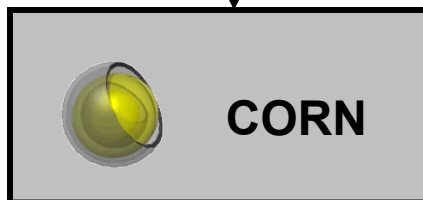



TEA: Thermodynamics for Engineering Applications

- Pure compound data library (extendible, or use DIPPR)
- 100+ Property calculation methods (25+ different properties)
- Property derivatives
- Support of external property calculation routines and external equilibrium servers

The screenshot shows two overlapping dialog boxes from the software. The top dialog, 'Property pack definition', has tabs for 'Property Calculations', 'Interaction Parameters', and 'Group Contributions'. It is currently on the 'General' tab, which contains a table of compounds and buttons for 'Add', 'Delete', 'Edit', and 'Up'. The bottom dialog, 'Add components', shows a 'PCD File' path and a 'Compound selection' table with columns for Name, Formula, Mol Weight, and CAS. A 'Filter by:' field is at the bottom of the second dialog.

Name	Formula	MW	CAS
Hydrogen	H2	2.01588	1333-74-0
Methane	CH4	16.0428	74-82-8
Benzene	C6H6	78.1136	71-43-2
Toluene	C7H8	92.1405	108-88-3
Biphenyl	C12H10	154.211	92-52-4

Name	Formula	Mol Weight	CAS
Air		28.9505	132259-10-0
Argon	Ar	39.948	7440-37-1
Bromine	Br2	159.808	7726-95-6
Carbon tetrachloride	CCl4	153.822	56-23-5
Carbon monoxide	CO	28.0104	630-08-0
Carbon dioxide	CO2	44.0098	124-38-9
Carbon disulfide	CS2	76.143	75-15-0
Phosgene	COCl2	98.9158	75-44-5
Trichloroacetyl chloride	C2OCl4	181.832	76-02-8
Hydrogen chloride	HCl	36.4606	7647-01-0
Chlorine	Cl2	70.9054	7782-50-5
Hydrogen iodide	HI	127.912	10034-85-2
Hydrogen	H2	2.01588	1333-74-0



COUSCOUS: Simple unit operations

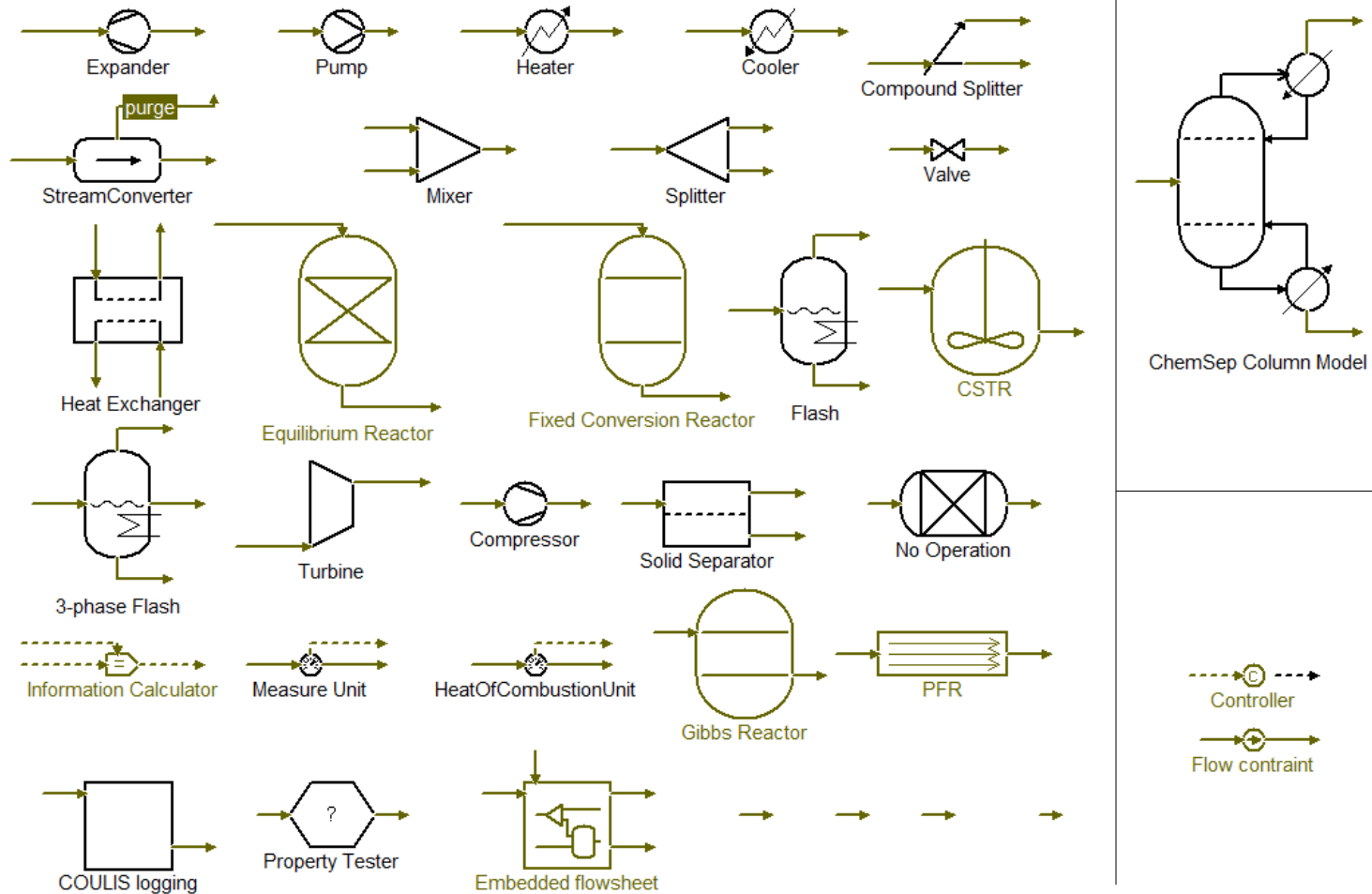



CORN: CAPE-OPEN Reaction Package

- Create reaction package
 - Define or import compounds
 - Define reactions with stoichiometry
 - Define reaction rates (or use Wizard) or equilibrium constant
 - Define reaction phase
- Insert reaction package into simulation
- Assign reaction package to reactor unit operation

The screenshot shows the 'Edit' dialog box for a reaction package. The 'Reaction' list on the left contains 'rxn1' and 'rxn2'. The 'Reaction properties' section on the right is configured as follows:

Stoichiometry	Compound
-1	Toluene
-1	Hydrogen
1	Benzene
1	Methane
0	Biphenyl

Additional properties and options:

- Equilibrium Reaction
- Heterogeneous
- Rate: $5.67e+009 \cdot \exp\{-22E\}$ mol/s/m²
- Equilibrium constant: [empty field]
- Equilibrium basis: [empty field]
- Heat of reaction: 0 J / mol
- Phase: Vapor

Buttons at the bottom: Create, Rename, Delete, Help, Load, Store, OK, Cancel.



Who/What is CAPE-OPEN?



CPI

Software vendors

Academic institutions

Other members

The CAPE-OPEN standard is the de facto standard for interfacing process modelling software components for use in the design and operation of chemical processes. It is based on universally recognised software technologies, such as COM and CORBA. The CO standard is open, multi-platform, uniform and available free of charge.

Luyben's Flowsheets

- **Pressure Swing Distillation of Acetone – Methanol**
- **Butanol / Water Separation**
- **THF / Water Separation with Heat Integration**
- **Cumene Process**
- **Column / Pervaporation Membrane Process (Ethanol / Water)**
- **Methanol from Syngas**
- **Butyl Acetate**
- **BTX Divided-Wall Column**

Pressure Swing Distillation of Acetone-Methanol

Ind. Eng. Chem. Res. (2008) 47 pp. 2696–2707

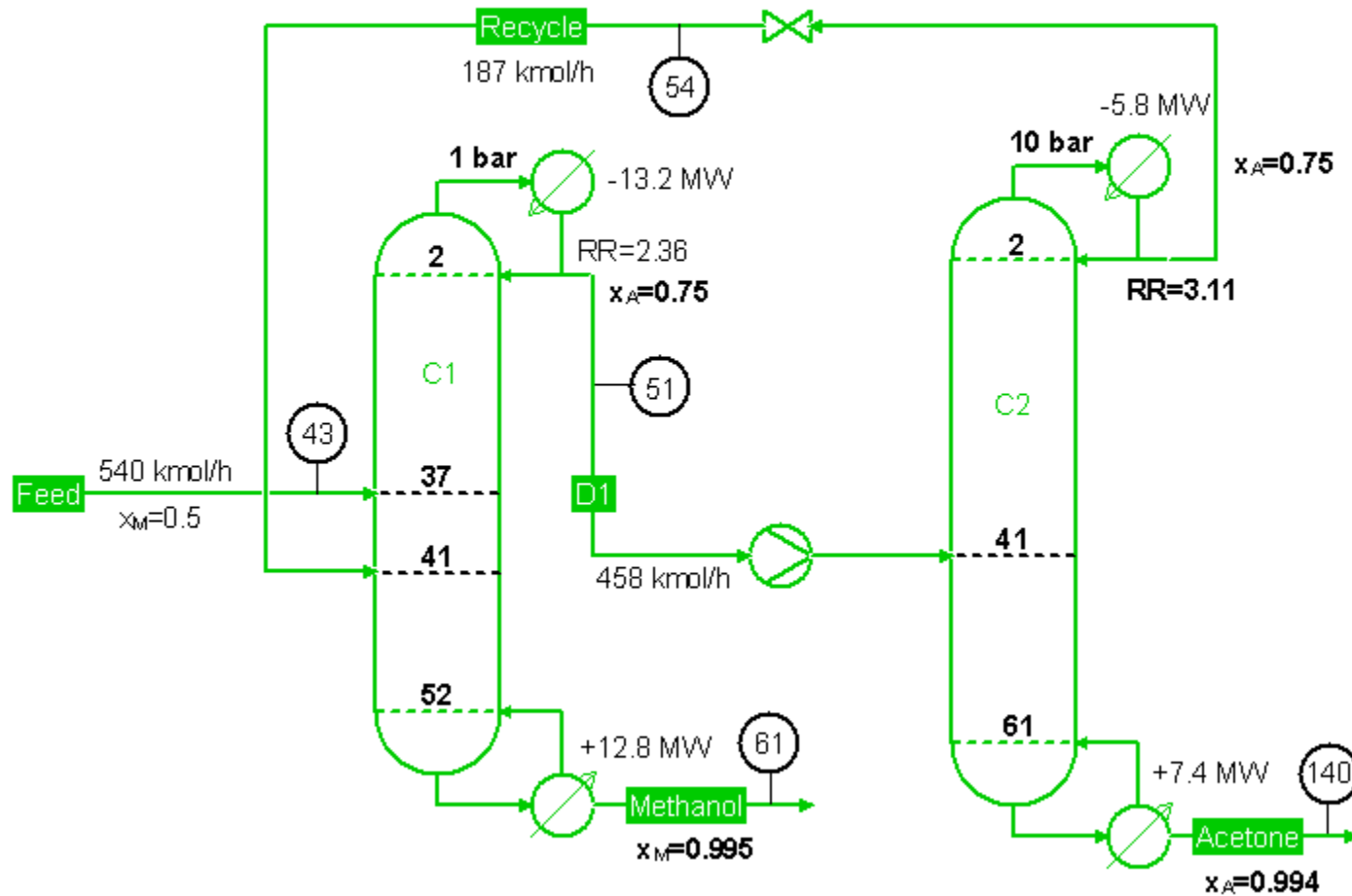

THF / Water Separation with Heat Integration

Design and Control of Distillation Systems for Separating Azeotropes / Ind. Eng. Chem. Res. (2008) 47 pp. 2681-2695

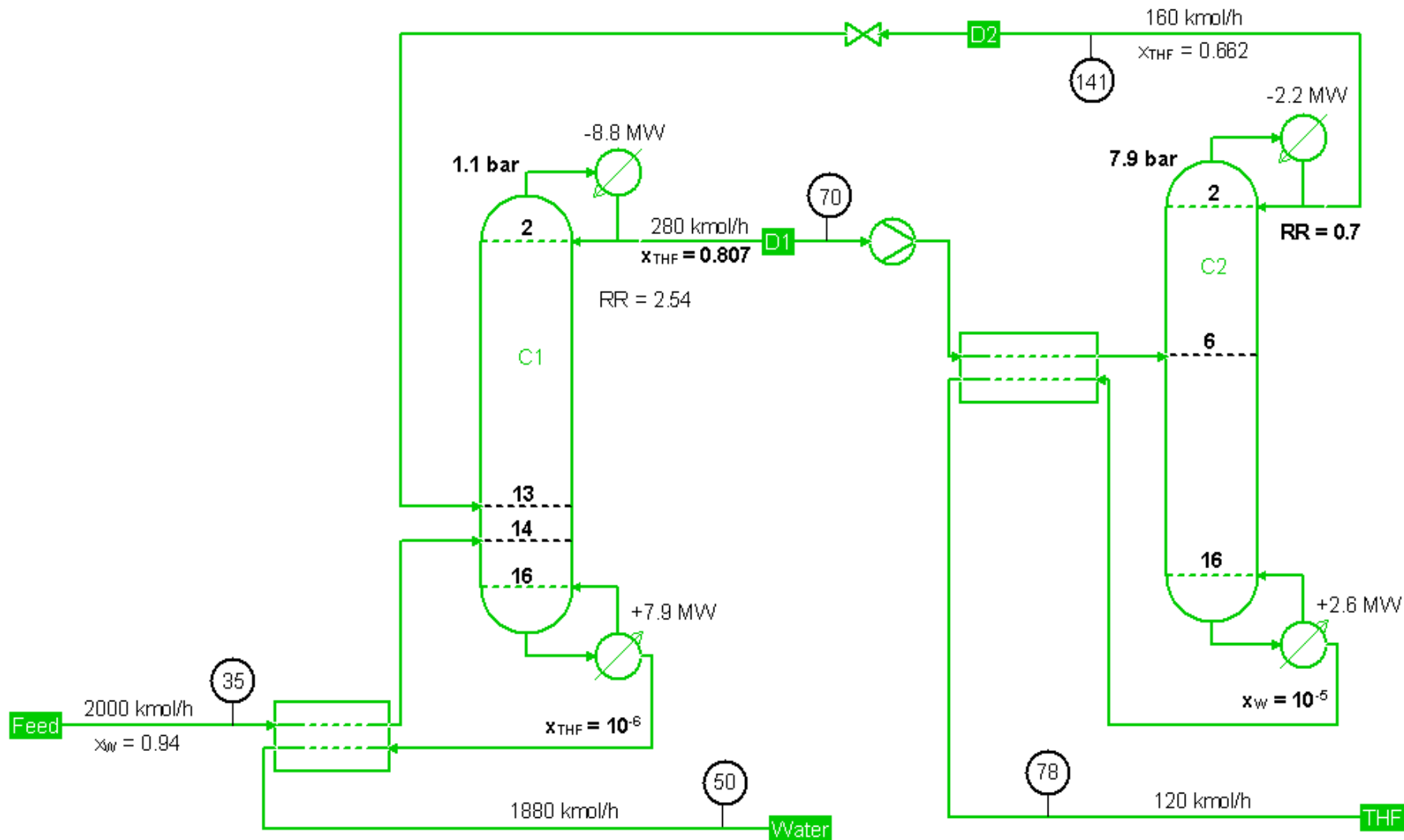

Cumene Process

Ind. Eng. Chem. Res. (2010) **49** pp. 719–734

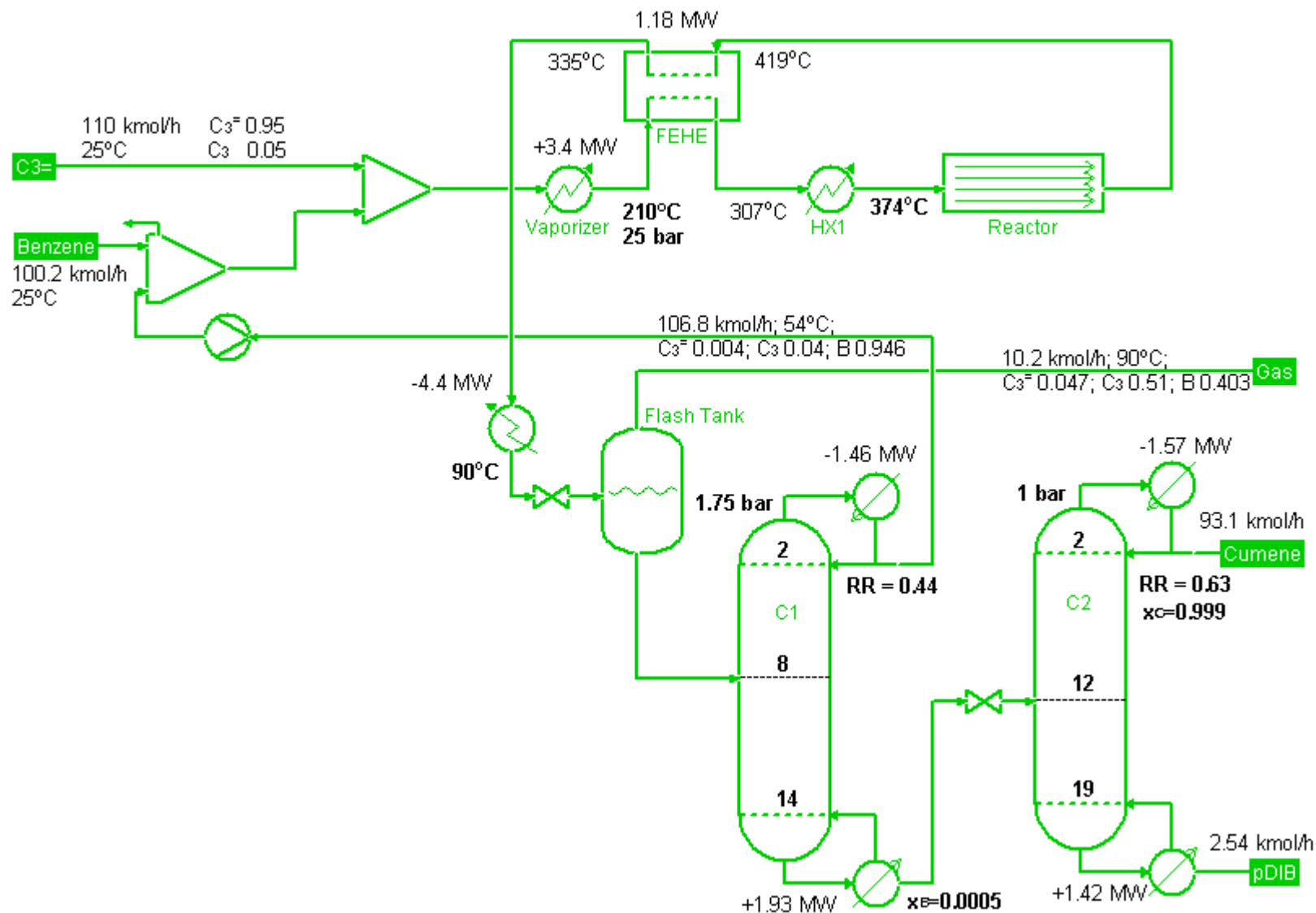

Column/Pervaporation Process for Separating Ethanol/Water

Ind. Eng. Chem. Res. (2009) **48** pp. 3484–3495

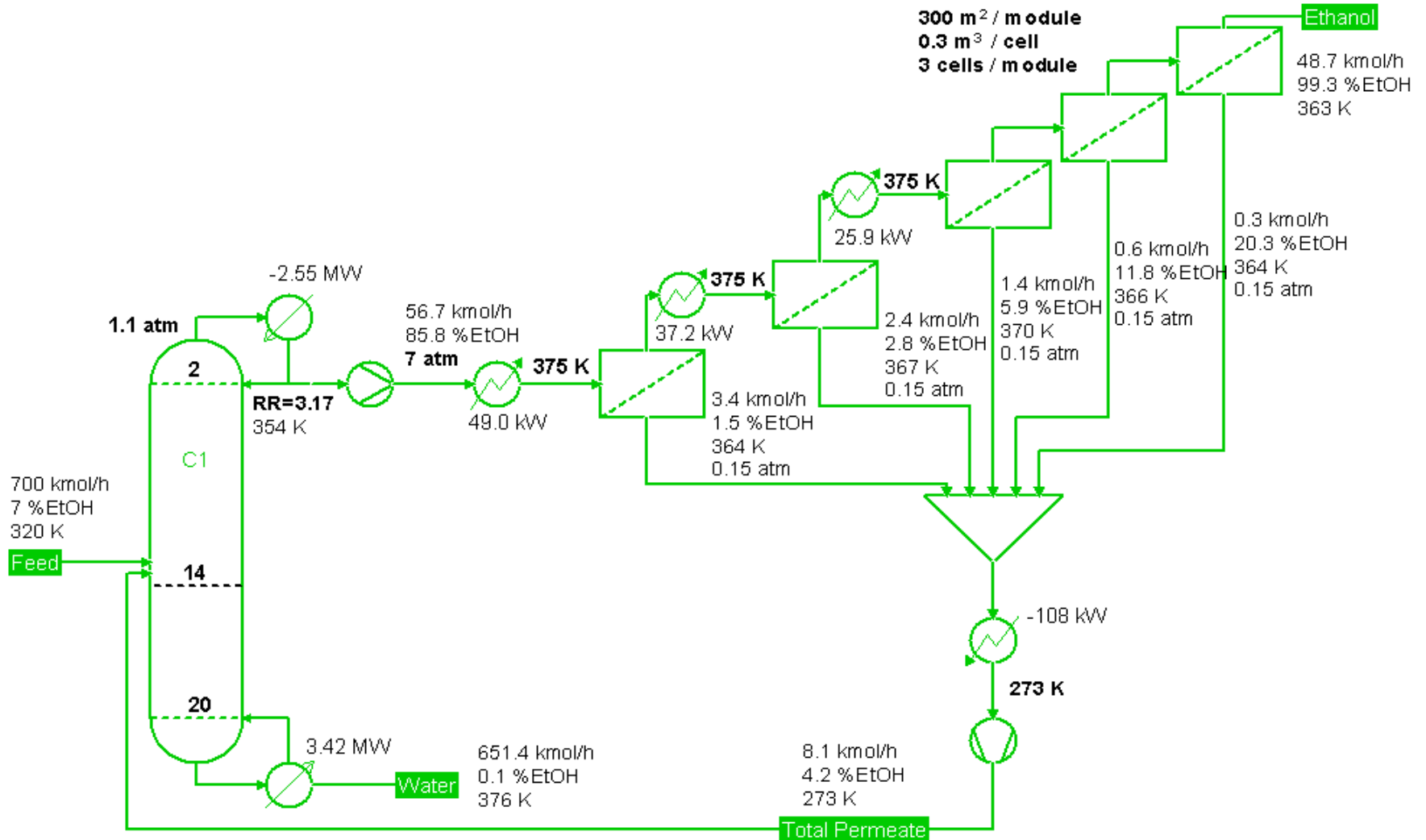

Methanol from Syngas

Ind. Eng. Chem. Res. (2010) **49** pp. 6150–6163

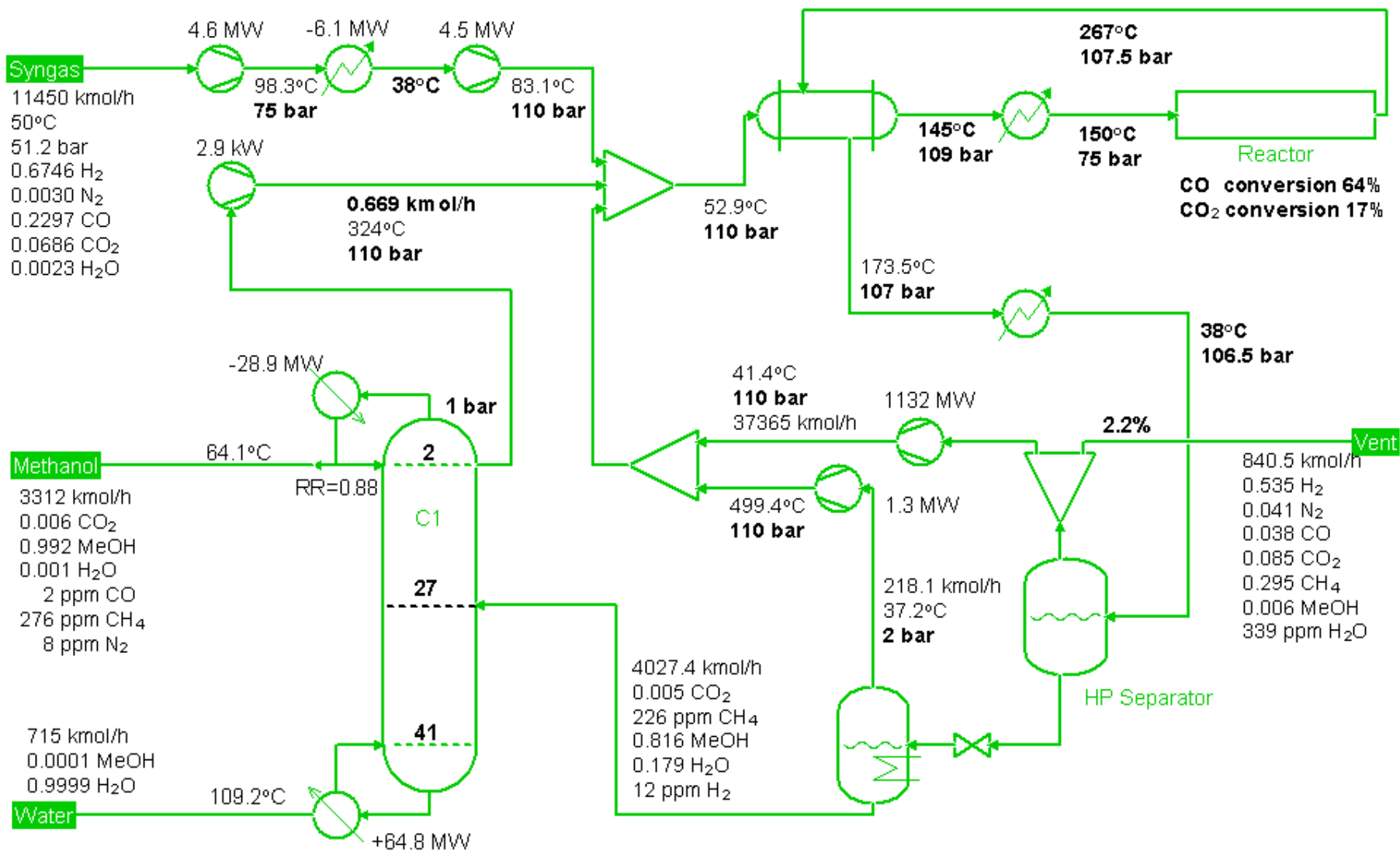

Butyl Acetate

Ind. Eng. Chem. Res. 2004, 43, 8014-8025

Ind. Eng. Chem. Res. 2011, 50, 1247-1263

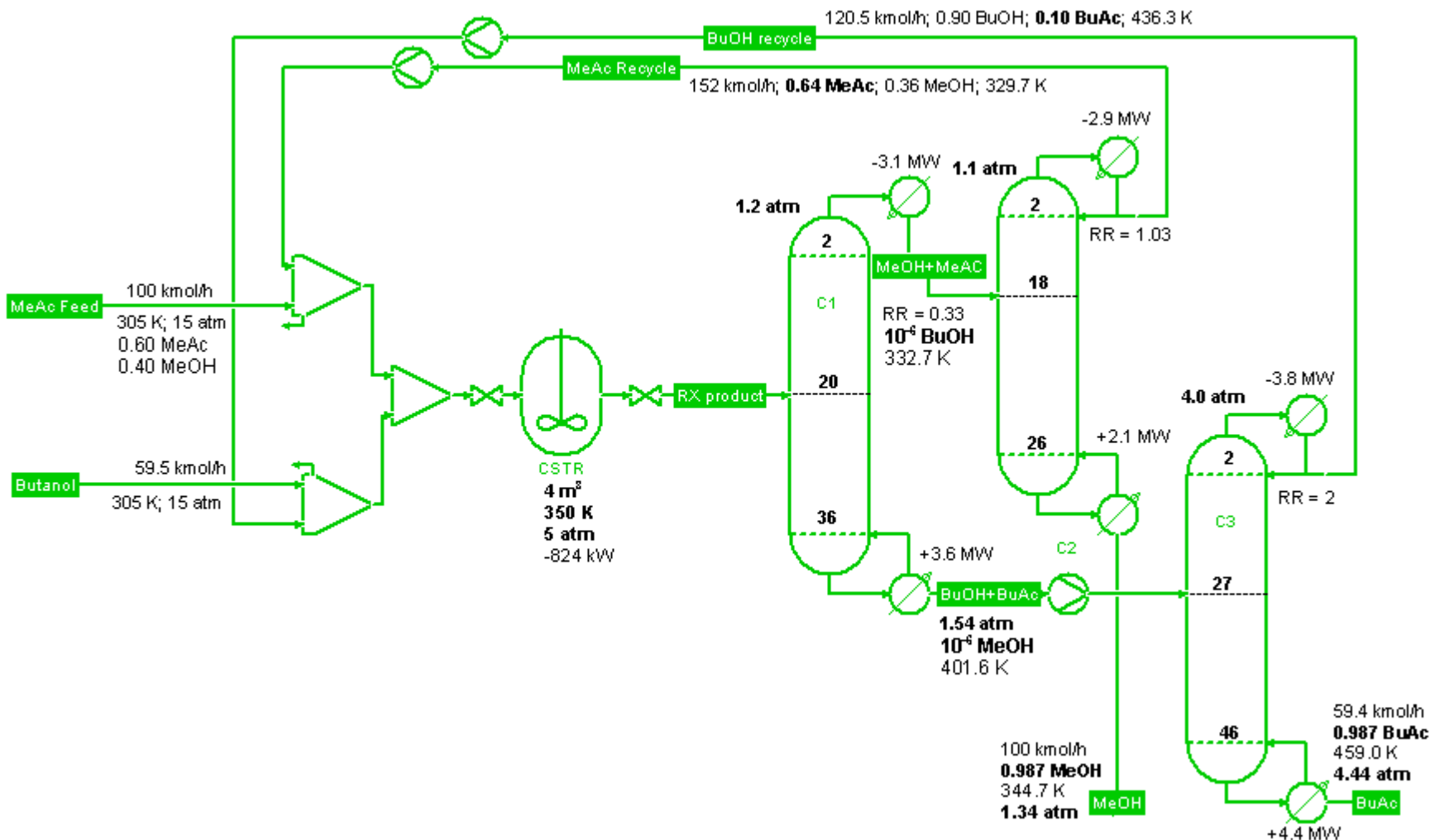

BTX Divided-Wall Column

Ind. Eng. Chem. Res. (2009) **48** pp. 6034–6049

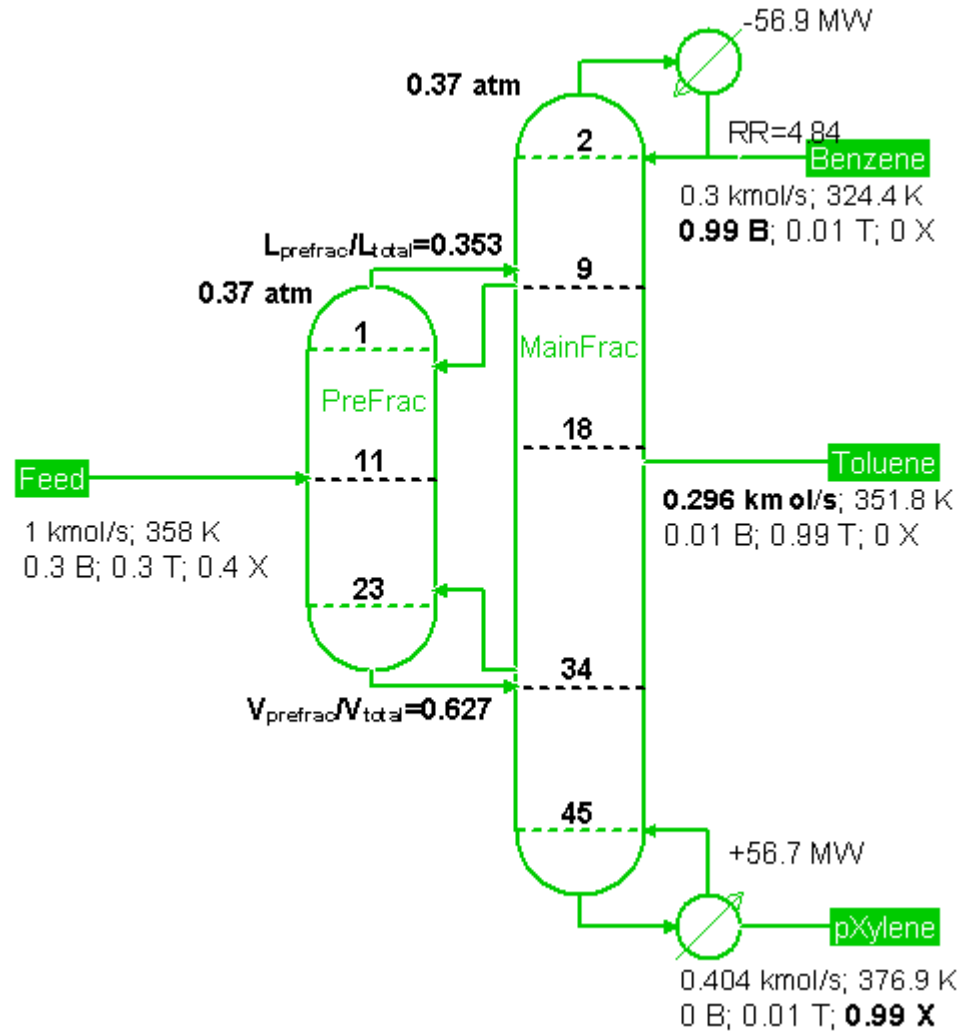

More Flowsheets

- **Ethyl Benzene** (*AIChE Journal*, 2011 **57**, 655)
- **Dimethylether** (*Distillation Design and Control using Aspen Simulation*)
- **Extractive Distillation**
- **Heterogeneous Ternary Distillation** (Alcohol-Water-Entrainer)
- **Reactive Distillation of $A + B \rightarrow C + D$**
- **TAME**
- **Air Separation Unit**
- **Ethylene Oxide**
- **Light Ends Unit**

Luyben's Flowsheets with COCO

- **Analysis**
- **Steady State Design**
- **Optimization**
- **Process Dynamics**
- **Control**

Some Lessons Learned

- Luyben's chemical processes can be modeled in steady state using COCO
- Some of Luyben's design specs need to be altered
- Results may differ – largely due to (slightly) different thermo
- Use of “make-up mixer” makes flowsheets much more robust to solve
- Use fixed conversion reactor before incorporating reaction kinetics
- To be useful in teaching design COCO/ChemSep need a databank for more compounds than exists at present; *databank extended for Luyben flowsheets + use up to 40 compounds in ChemSep v6.9 columns!*
- COCO no more difficult to learn to use than UNISIM Design (UD)
- COCO useful in mass and energy balances class where simple component splitter models and conversion reactors are typical

Luyben's Flowsheets: Can we please have some more?

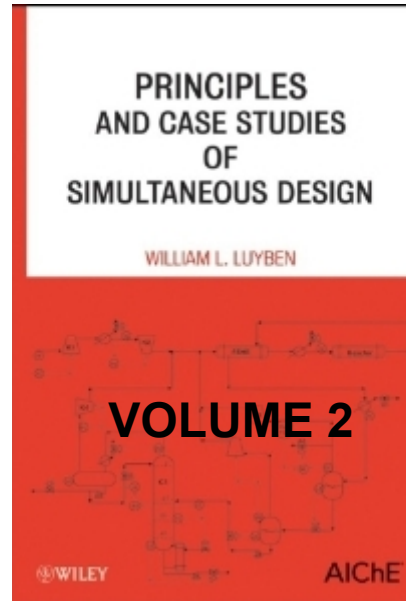

2012 / 2013 ?